

Mit Liebe zum Detail



# Fitness

International 2010



Inhalt

Content

## SYGNUM Standards

Obere Extremität Upper Extremities .....	8
Rumpf / Trunk .....	13
Untere Extremität Lower Extremities .....	16
Universell / Total Body Workout .....	19

## SYGNUM Dual

Obere Extremität Upper Extremities .....	24
Untere Extremität Lower Extremities .....	25

## SYGNUM Innovation

Obere Extremität Upper Extremities .....	28
Rumpf / Trunk .....	28
Untere Extremität Lower Extremities .....	28
Universell / Total Body Workout .....	29

## SYGNUM Cable Art

Universell einsetzbar Universell / Total Body Workout .....	32
--	----

## SYGNUM Plate Loaded

Obere Extremität Upper Extremities .....	36
Rumpf / Trunk .....	37
Untere Extremität Lower Extremities .....	38

## SYGNUM Functional

Universell / Total Body Workout .....	41
---------------------------------------	----

## SYGNUM Basic

Obere Extremität Upper Extremities .....	44
Rumpf / Trunk .....	46
Untere Extremität Lower Extremities .....	47
Universell / Total Body Workout .....	48

## Zubehör

Accessories .....	52
-------------------	----

## Design und Farben

Design and Colours .....	58
--------------------------	----

## circular

Obere Extremität Upper Extremities .....	62
Rumpf / Trunk .....	63
Untere Extremität Lower Extremities .....	64

enforbike® .....	66
------------------	----

gym80-Software 3.0 .....	68
--------------------------	----

## Konzepte

### Concepts

K <sup>3</sup> -Konzept / K <sup>3</sup> -Concept .....	80
SYGNUM High Performance Fußball-Konzept / Soccer Concept .....	81
Cable Art Trainingskonzept Cable Art Training Concept .....	82
SynergyCycling .....	83

Impressum .....	84
-----------------	----

## Unser Ziel - Ihre Zufriedenheit Our aim - your satisfaction

// Hinter allem, was wir tun, steht immer derselbe Gedanke: Ihnen allerhöchste Qualität zu bieten. Qualität, die sich nicht nur in unseren Produkten „Made in Germany“ widerspiegelt, sondern auch in allen anderen von uns angebotenen Leistungen. Denn bei gym80 International bekommen Sie alles aus einer Hand. Wir bieten Ihnen Lösungen für jeden Anspruch und für jede Größe, im Fitness-, Medical- und High-Performance-Bereich. Unsere Lösungen gehen weit über das normale Geräteangebot hinaus. Neben einer passenden Studioausstattung bekommen Sie bei uns nämlich auch eine umfassende Beratung, eine auf Sie zugeschnittene Finanzierung und eines, was Sie ganz sicher zu schätzen wissen: Kundennähe. Denn die ist bei uns nicht Mittel zum Zweck, sondern Teil unserer Philosophie.

// All our actions are driven by the same guiding aim: to offer you the very highest quality. Quality that is reflected not only in our “Made in Germany” products, but also in all the other services we provide. gym80 International provides everything you need from a single source. We can offer you solutions for every possible requirement and size, for fitness, medical and high performance applications. Our solutions go far beyond a standard equipment range. As well as the right studio equipment, we can also provide you with comprehensive advice, tailored financing and something you are sure to appreciate: proximity to our customers. For us, this is not simply a means to an end, it's an integral part of our philosophy.





## SYGNUM Standards

// SYGNUM Standards bietet die ideale Grundausstattung für jedes Studio. Sie sind die klassische Grundausstattung mit Steckgewichten für das Ganzkörper-Workout und decken das Training aller wichtigen Muskelgruppen ab. Für jede dieser Gruppen gibt es verschiedene Geräte, so dass jeder Muskel abwechslungsreich trainiert werden kann.

// SYGNUM Standards offers the ideal basic equipment for any fitness center. This comprises classic equipment with removable weights to provide a whole-body workout, covering all main muscle groups. Different machines are available for each of these groups, to allow each muscle to be trained in a variety of ways.



### // Besonderheiten / Features

Unterschiedliche Maschinen für dieselbe Muskelgruppe / Perfekte Biomechanik / 4 mm Stahlrohre ohne Verschraubung / Anschluss für gym80-Trainingssoftware (optional) / Individuelle Farbwahl für Polster, Rahmen und Gewichtsverkleidung / Auf Anfrage erhöhte Gewichtspakete / Different machines for the same muscle groups / Perfect biomechanics / 4 mm steel tube without bolts / Connection for gym80 training software (optional) / Individual selection of colors for upholstery, frames and weight coverings / Upgrade weight stack on request

Damit sich die Muskeln nicht langweilen – To prevent the muscles from getting bored



**00003010**

Bizepsmaschine  
Biceps Curl Machine

Länge/length	1000 mm
Breite/width	1100 mm
Höhe/height	1570 mm
Gewichtspaket/weight stack	85 kg

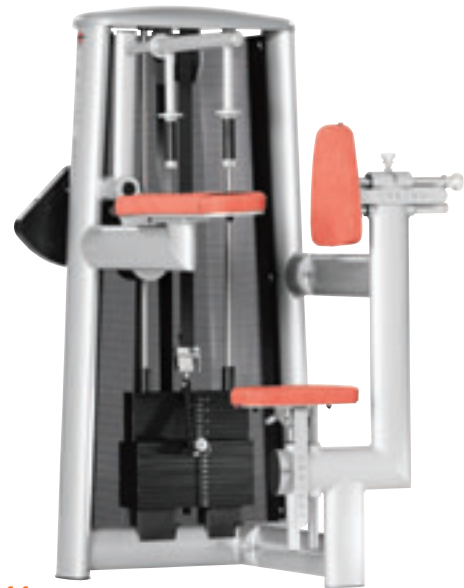
**00003011**

Trizepsmaschine Horizontal  
Triceps Machine Horizontal

Länge/length	1000 mm
Breite/width	1100 mm
Höhe/height	1570 mm
Gewichtspaket/weight stack	85 kg

**00003012**

Überzugmaschine  
Pull Over Machine

Länge/length	1720 mm
Breite/width	1120 mm
Höhe/height	1570 mm
Gewichtspaket/weight stack	105 kg

**00003014**

Brustmaschine  
Crossover Machine

Länge/length	1100 mm
Breite/width	1100 mm
Höhe/height	1680 mm
Gewichtspaket/weight stack	85 kg





**00003015**

Seithebemaschine  
Deltoid Raise Machine

Länge/length	1300 mm
Breite/width	1200 mm
Höhe/height	1570 mm
Gewichtspaket/weight stack	85 kg



**00003210**

Bankdrückmaschine  
Seated Chest Press Machine

Länge/length	1350 mm
Breite/width	1510 mm
Höhe/height	1570 mm
Gewichtspaket/weight stack	105 kg



**00003017**

Klimmzug-, Barrenmaschine  
Kneeling Chinning and Dipping Machine

Länge/length	1450 mm
Breite/width	1560 mm
Höhe/height	2280 mm
Gewichtspaket/weight stack	135 kg



**00003020**

Rückenzugmaschine  
Lat Pulley Machine

Länge/length	1650 mm
Breite/width	1470 mm
Höhe/height	2100 mm
Gewichtspaket/weight stack	135 kg



**00003021**

Butterfly mit Unterarmpolstern  
Butterfly with forearm pads

Länge/length	1770 mm
Breite/width	1100 mm
Höhe/height	1790 mm
Gewichtspaket/weight stack	105 kg

**00003022**

Butterfly mit Handgriffen  
Butterfly with hand grips

Länge/length	1770 mm
Breite/width	1460 mm
Höhe/height	1790 mm
Gewichtspaket/weight stack	105 kg

**00003023**

Schrägbankmaschine  
Incline Bench Press Machine

Länge/length	2050 mm
Breite/width	1510 mm
Höhe/height	1570 mm
Gewichtspaket/weight stack	105 kg

**00003025**

Rückenmaschine  
Upper Back Machine

Länge/length	1300 mm
Breite/width	760 mm
Höhe/height	1790 mm
Gewichtspaket/weight stack	105 kg





**00003032**

Schultermaschine  
Shoulder Press Machine

Länge/length	2100 mm
Breite/width	1500 mm
Höhe/height	1570 mm
Gewichtspaket/weight stack	85 kg



**00003036**

Trizepsmaschine Vertikal  
Triceps Machine Vertical

Länge/length	1400 mm
Breite/width	1630 mm
Höhe/height	1570 mm
Gewichtspaket/weight stack	135 kg



**00003039**

Rudermaschine ohne Brustpolster  
Seated Rowing Machine without chest pad

Länge/length	1520 mm
Breite/width	1160 mm
Höhe/height	1570 mm
Gewichtspaket/weight stack	135 kg



**00004032**

4-Stationen-Turm  
4-Station Tower

Länge/length	3050 mm
Breite/width	1200 mm
Höhe/height	2400 mm
Gewichtspaket/weight stack	3 x 135 kg 1 x 85 kg



**00003040**

Rudermaschine mit Brustpolster  
Seated Rowing Machine with chest pad

Länge/length	1300 mm
Breite/width	1200 mm
Höhe/height	1620 mm
Gewichtspaket/weight stack	135 kg

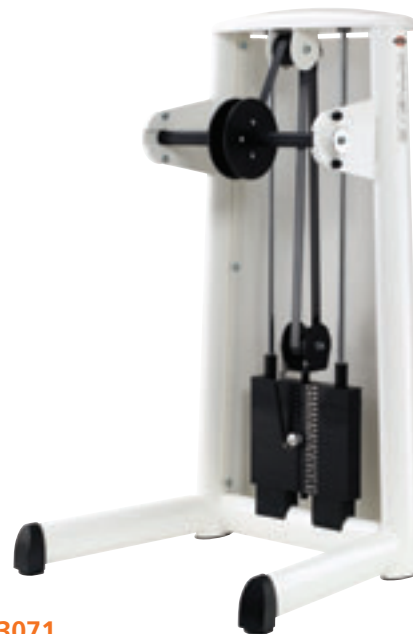
**00003071**

Unterarmmaschine  
Lower Arm Machine

Länge/length	930 mm
Breite/width	930 mm
Höhe/height	1600 mm
Gewichtspaket/weight stack	55 kg

**00004015**

Rückenzugstation  
Lat Pulley

Länge/length	870 mm
Breite/width	750 mm
Höhe/height	2370 mm
Gewichtspaket/weight stack	135 kg

**00004016**

Rudersstation  
Long Pulley

Länge/length	2240 mm
Breite/width	750 mm
Höhe/height	2370 mm
Gewichtspaket/weight stack	135 kg







**00003007**

Rückenstreckmaschine  
Lower Back Machine

Länge/length	1380 mm
Breite/width	1080 mm
Höhe/height	1570 mm
Gewichtspaket/weight stack	105 kg

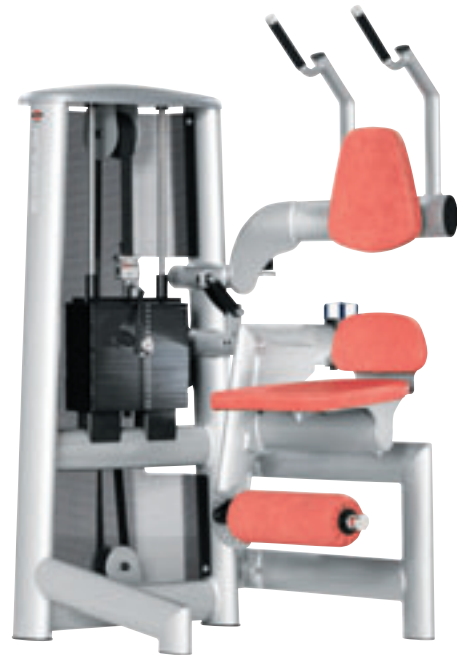

**00003008**

Bauchmuskelmachine  
Abdominal Machine

Länge/length	1050 mm
Breite/width	1080 mm
Höhe/height	1570 mm
Gewichtspaket/weight stack	105 kg

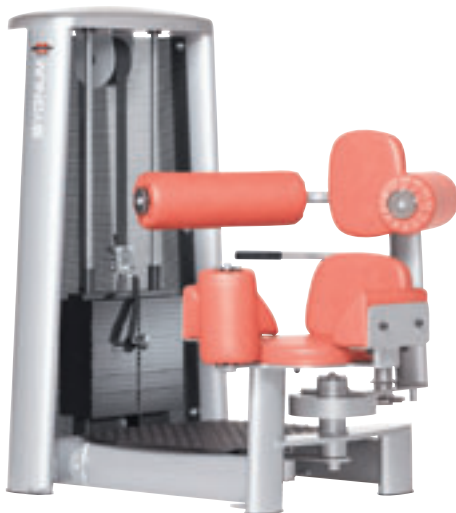

**00003024**

Twistermaschine  
Twister Machine

Länge/length	850 mm
Breite/width	1480 mm
Höhe/height	1270 mm
Gewichtspaket/weight stack	85 kg



**00003034**

Bauchmuskelmachine liegend  
Lying Abdominal Machine

Länge/length	1570 mm
Breite/width	1060 mm
Höhe/height	1570 mm
Gewichtspaket/weight stack	105 kg



**00003035**

Beckenlift  
Pelvis lifter

Länge/length	2000 mm
Breite/width	1250 mm
Höhe/height	1570 mm
Gewichtspaket/weight stack	135 kg

**00003037**

Bauchmuskelmachine mit Beinlängen Anpassung  
Special Abdominal Machine

Länge/length	950 mm
Breite/width	1150 mm
Höhe/height	1570 mm
Gewichtspaket/weight stack	105 kg

**00003038**

Rückenstrecker mit Beinlängen Anpassung  
Lower Back Machine

Länge/length	1700 mm
Breite/width	1200 mm
Höhe/height	1600 mm
Gewichtspaket/weight stack	105 kg





**00003001**

Beinstrecker  
Leg Extension

Länge/length	1040 mm
Breite/width	1100 mm
Höhe/height	1570 mm
Gewichtspaket/weight stack	135 kg



**00003002**

Beinbeuger liegend  
Lying Leg Curl

Länge/length	1750 mm
Breite/width	1100 mm
Höhe/height	1570 mm
Gewichtspaket/weight stack	85 kg



**00003003**

Beinbeuger sitzend  
Seated Leg Curl

Länge/length	1170 mm
Breite/width	1160 mm
Höhe/height	1570 mm
Gewichtspaket/weight stack	135 kg



**00003004**

Glutaeus kniend/liegend  
Gluteus kneeling/lying

Länge/length	1550 mm
Breite/width	1120 mm
Höhe/height	1570 mm
Gewichtspaket/weight stack	85 kg





**00003005**

Glutaeusmaschine Radial  
Gluteus Machine Radial

Länge/length	1100 mm
Breite/width	1100 mm
Höhe/height	1570 mm
Gewichtspaket/weight stack	85 kg

**00003006**

Kickmaschine  
Total Hip Machine

Länge/length	1420 mm
Breite/width	1060 mm
Höhe/height	1640 mm
Gewichtspaket/weight stack	105 kg

**00003013**

Beinbeuger stehend  
Standing Leg Curl

Länge/length	900 mm
Breite/width	1200 mm
Höhe/height	1570 mm
Gewichtspaket/weight stack	85 kg

**00003018**

Wadenmaschine stehend  
Standing Calf Machine

Länge/length	1120 mm
Breite/width	1040 mm
Höhe/height	2000 mm
Gewichtspaket/weight stack	135 kg





**00003027**

Wadenmaschine sitzend  
Seated Calf Machine

Länge/length	1400 mm
Breite/width	1180 mm
Höhe/height	1570 mm
Gewichtspaket/weight stack	135 kg



**00003028**

Abduktionsmaschine  
Abduction Machine

Länge/length	1700 mm
Breite/width	800 mm
Höhe/height	1270 mm
Gewichtspaket/weight stack	105 kg



**00003029**

Adduktionsmaschine  
Adduction Machine

Länge/length	1700 mm
Breite/width	1580 mm
Höhe/height	1270 mm
Gewichtspaket/weight stack	105 kg



**00003030**

Beinpresse sitzend  
Seated Leg Press

Länge/length	2040 mm
Breite/width	1250 mm
Höhe/height	1570 mm
Gewichtspaket/weight stack	245 kg

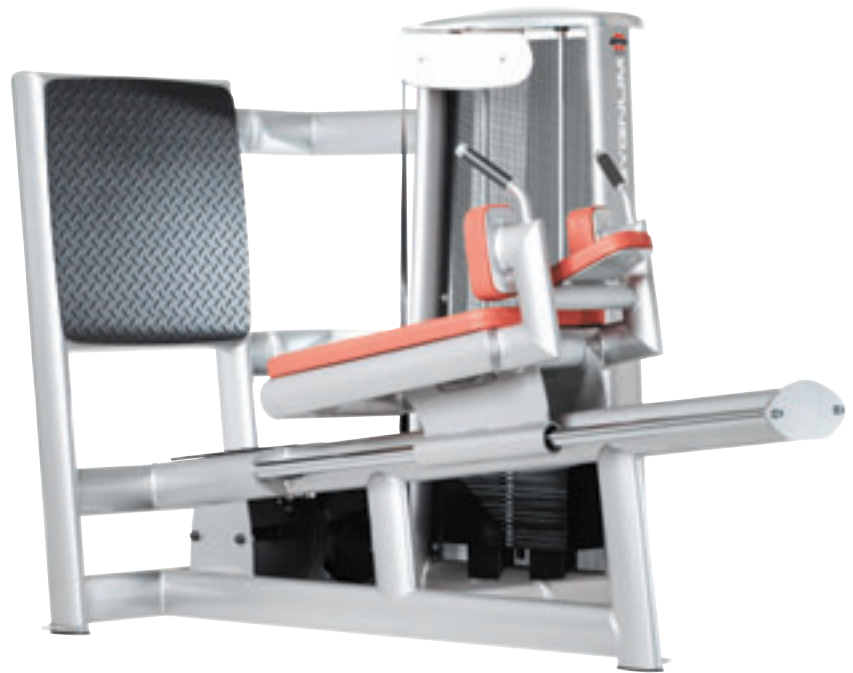

**00003031**

Beinpresse liegend  
Lying Leg Press Machine

Länge/length	2040 mm
Breite/width	1250 mm
Höhe/height	1570 mm
Gewichtspaket/weight stack	245 kg



Universell / Total Body Workout

**00004004**

Kabelzugstation mit Klimmzugstange  
Cable Crossover Station with chinning bar

Länge/length	3460 mm
Breite/width	760 mm
Höhe/height	2280 mm
Gewichtspaket/weight stack	2 x 85 kg



NOTIZEN / NOTES

//



**00004033**Doppelstation  
Duplex Station

Länge/length	1130 mm
Breite/width	760 mm
Höhe/height	2100 mm
Gewichtspaket/weight stack	1 x 105 kg 1 x 85 kg

**00004036**Multidrückstation mit Steckgewichten  
Multipress with weight stacks

Länge/length	900 mm
Breite/width	2150 mm
Höhe/height	2300 mm
Gewichtspaket/weight stack	2 x 70 kg

**00004041**Einzelstation höhenverstellbar  
Singlestation height adjustable

Länge/length	1070 mm
Breite/width	1050 mm
Höhe/height	2380 mm
Gewichtspaket/weight stack	85 kg

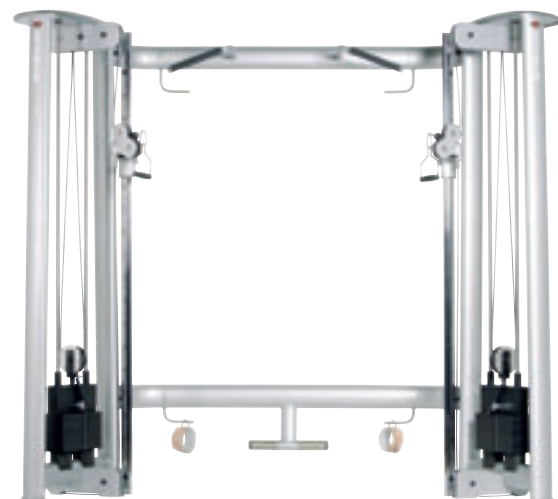
**00004042**V-Station höhenverstellbar  
V-Pulley height adjustable

Länge/length	2540 mm
Breite/width	1000 mm
Höhe/height	2380 mm
Gewichtspaket/weight stack	2 x 85 kg



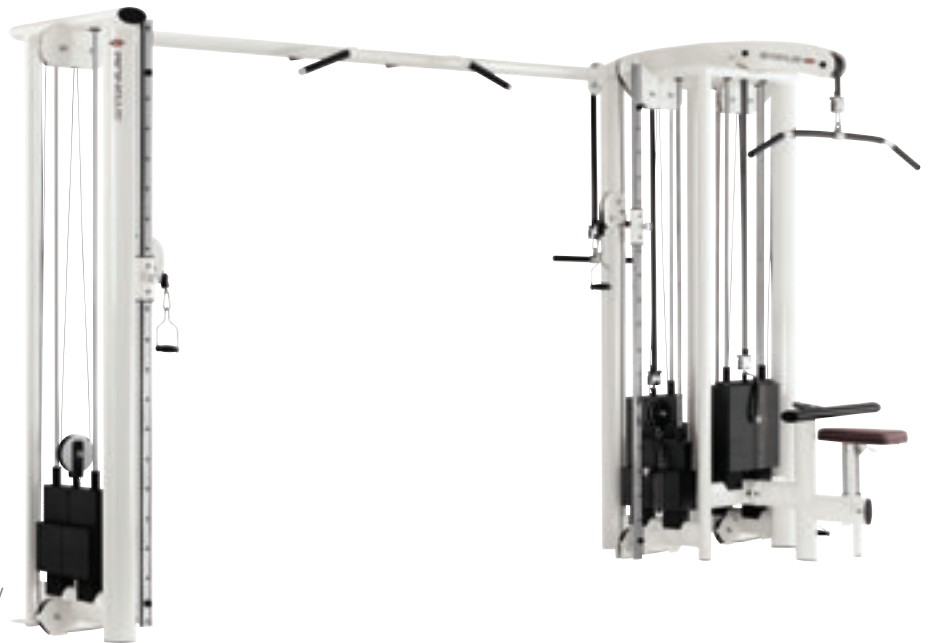

**00004044**

5-Stationen-Turm opt. mit Long Pulley  
5-Station Tower opt. with Long Pulley

Länge/length	4600 mm
Breite/width	1600 mm
Höhe/height	2400 mm
Gewichtspaket/weight stack	1 x 135 kg
	4 x 85 kg



NOTIZEN / NOTES

## SYGNUM Dual

// SYGNUM Dual fördert durch zwei unabhängig voneinander gelagerte Lastarme die Koordinationsfähigkeit des Trainierenden. Mit SYGNUM Dual können Sie jede Körperhälfte separat trainieren, was den Ausgleich muskulärer Dysbalancen ermöglicht. Dank der optimalen Biomechanik ist eine ideale Bewegungsführung jederzeit garantiert.

// SYGNUM DUAL uses two independently functioning load arms to improve the user's coordination. SYGNUM DUAL allows you to train each side of the body separately to alleviate muscular imbalances. Optimal biomechanics guide the user's movements at all times.





#### // Besonderheiten / Features

Zwei unabhängig voneinander gelagerte Lastarme / Perfekte Biomechanik / 4 mm Stahlrohre ohne Verschraubung / Anschluss für gym80-Trainingssoftware (optional) / Individuelle Farbwahl für Polster, Rahmen und Gewichtsverkleidung / Auf Anfrage erhöhte Gewichtspakete / Two independently functioning load arms / Perfect biomechanics / 4 mm steel tube without bolts / Connection for gym80 training software (optional) / Individual selection of colors for upholstery, frames and weight coverings / Upgrade weight stack on request

Damit Links und Rechts wieder ein Ganzes werden.



**00003041**

Bankdrückmaschine Dual  
Chest Press Machine Dual

Länge/length	1660 mm
Breite/width	1850 mm
Höhe/height	1570 mm
Gewichtspaket/weight stack	105 kg

**00003042**

Schrägbankmaschine Dual  
Incline Bench Press Machine Dual

Länge/length	2100 mm
Breite/width	1640 mm
Höhe/height	1570 mm
Gewichtspaket/weight stack	105 kg

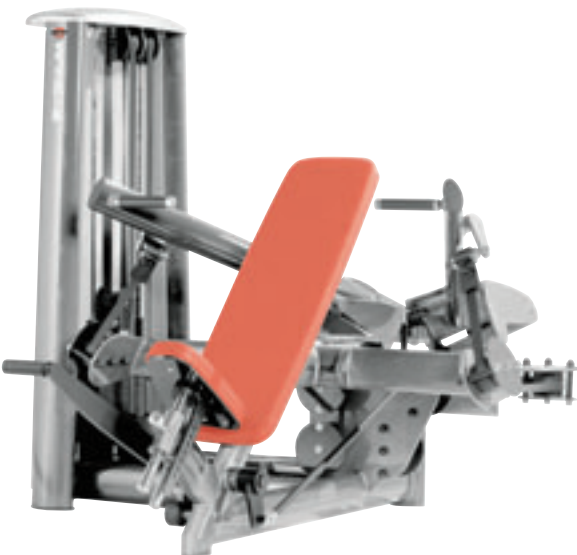
**00003043**

Schultermaschine Dual  
Shoulder Press Machine Dual

Länge/length	2180 mm
Breite/width	1800 mm
Höhe/height	1570 mm
Gewichtspaket/weight stack	85 kg

**00003044**

Rückenzugmaschine Dual  
Lat Pulldown Machine Dual

Länge/length	1680 mm
Breite/width	1400 mm
Höhe/height	2250 mm
Gewichtspaket/weight stack	135 kg





**00003045**

Rudermaschine Dual  
Seated Rowing Machine Dual

Länge/length	1800 mm
Breite/width	1220 mm
Höhe/height	1570 mm
Gewichtspaket/weight stack	135 kg



**00003046**

Beinpresse mit Steckgewicht Dual  
Leg Press Dual

Länge/length	2200 mm
Breite/width	1800 mm
Höhe/height	1850 mm
Gewichtspaket/weight stack	2 x 165 kg



NOTIZEN / NOTES

## SYGNUM Innovation

// Mit unserer Linie SYGNUM Innovation werden komplexe Muskelbereiche trainiert, die in einem natürlichen Bewegungskontext zusammenarbeiten. Bei diesem Muskelschlingen-Training werden die zusammenhängenden Muskelketten aktiviert und lernen, als Einheit zu agieren. Die Stabilität des trainierten Bereichs wird verbessert. In Verbindung mit SYGNUM Standards sorgt SYGNUM Innovation für die ideale Ausstattung jedes Studios.

// Our SYGNUM Innovation line trains complex muscle groups which normally work together in natural movement. This muscle loop training stimulates connected muscle chains and teaches them how to work together as a homogenous unit, helping to improve the stability of the area being trained. In combination with SYGNUM Standards, SYGNUM Innovation is the ideal equipment for any fitness center.



#### // Besonderheiten / Features

Training komplexer Muskelbereiche / Kompletter Bewegungsablauf / Perfekte Biomechanik / Anschluss für gym80-Trainingssoftware (optional) / Individuelle Farbwahl für Polster, Rahmen und Gewichtsverkleidung / Auf Anfrage erhöhte Gewichtspakete / Trains complex muscle groups / Complete motion sequence / Perfect biomechanics / Connection for gym80 training software (optional) / Individual selection of colors for upholstery, frames and weight coverings / Upgrade weight stack on request

**00005004**

Curler

Länge/length	1270 mm
Breite/width	1880 mm
Höhe/height	1570 mm
Gewichtspaket/weight stack	85 kg

**00005006**Streckschlinge  
Back Stretch Multi Joint Machine

Länge/length	1240 mm
Breite/width	1160 mm
Höhe/height	1640 mm
Gewichtspaket/weight stack	135 kg

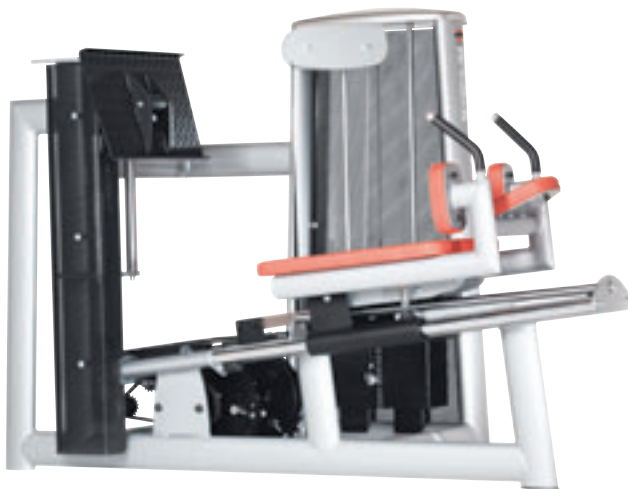

## Untere Extremität / Lower Extremities

**00005001**Beinpresse  
Leg Press

Länge/length	2150 mm
Breite/width	1250 mm
Höhe/height	1570 mm
Gewichtspaket/weight stack	214 kg

**00005002**

Gluteus

Länge/length	1300 mm
Breite/width	1380 mm
Höhe/height	2500 mm
Gewichtspaket/weight stack	135 kg





**00005003**

Rower

Länge/length	2110 mm
Breite/width	1120 mm
Höhe/height	1570 mm
Gewichtspaket/weight stack	135 kg



NOTIZEN / NOTES

## SYGNUM

Cable Art

// SYGNUM Cable Art ermöglicht dem Trainierenden, die Übungen ganz nach seinen persönlichen Vorstellungen auszuführen. Die Bewegungen sind ungeführt, die Bahnen sind frei, der Radius ist jederzeit individuell bestimmbar. In jeder Maschine befinden sich zwei Gewichtspakete, die es dem Trainierenden ermöglichen, beide Körperhälften unabhängig voneinander und mit unterschiedlichen Gewichten zu trainieren. Neben jeweils zwei Grundübungen sind pro Gerät auch zahlreiche Alternativübungen möglich.

// SYGNUM Cable Art allows each user to tailor the exercises precisely to his or her personal needs. Movements are unguided, lines are free and the radius can be specified individually at any time. Each machine contains two weight stacks which allow the user to train each side of the body independently using different weights. In addition to two basic exercises, a wide range of alternative movements can be performed on each machine.





### // Besonderheiten / Features

Ungeführte Bewegungen, freie Bahnen / Trainingskonzept Cable Art / Beide Körperhälften unabhängig voneinander trainierbar / Perfekte Biomechanik / Individuelle Farbwahl für Polster, Rahmen und Gewichtsverkleidung / Auf Anfrage erhöhte Gewichtspakete / Un-guided movements, free lines / Cable Art training concept / Each side of the body can be trained independently / Perfect biomechanics / Individual selection of colors for cushions, frames and weight coverings / Upgrade weight stack on request

Diese Freiheit haben Sie sich verdient – You have earned this freedom



**00005101**

## Cable Art 1

Trainiert die Armbeuge- und Armstreckmuskulatur.  
Alternativübungen möglich.

Strengthening of the arm muscles.  
Alternative exercises are possible.

Länge/length	1500 mm
Breite/width	1300 mm
Höhe/height	1820 mm
Gewichtspaket/weight stack	2 x 55 kg

**00005102**

## Cable Art 2

Trainiert die Rückenmuskulatur.  
Alternativübungen möglich.

Strengthening of the back and shoulder muscles.  
Alternative exercises are possible.

Länge/length	1400 mm
Breite/width	1300 mm
Höhe/height	2420 mm
Gewichtspaket/weight stack	2 x 105 kg

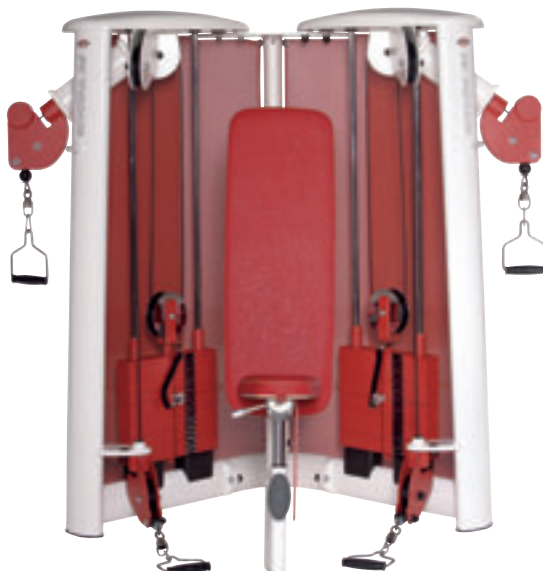
**00005103**

## Cable Art 3

Trainiert die Brust- und Schultermuskulatur.  
Alternativübungen möglich.

Strengthening of the chest and shoulder muscles.  
Alternative exercises are possible.

Länge/length	1760 mm
Breite/width	1500 mm
Höhe/height	1820 mm
Gewichtspaket/weight stack	2 x 55 kg





**00005104**

Cable Art 4

Trainiert die Armstreck-, Schulter- und Rückenmuskulatur. Alternativübungen möglich.

Strengthening of the shoulder and arm muscles. Alternative exercises are possible.

Länge/length	1600 mm
Breite/width	1300 mm
Höhe/height	1950 mm
Gewichtspaket/weight stack	2 x 55 kg



**00005105**

Cable Art 5

Trainiert die Bauch- und Schultermuskulatur. Alternativübungen möglich.

Strengthening of the shoulder and stomach muscles. Alternative exercises are possible.

Länge/length	1300 mm
Breite/width	1300 mm
Höhe/height	1860 mm
Gewichtspaket/weight stack	2 x 55 kg



**00005106**

Cable Art 6

Trainiert die Beinstreck- und Beinbeugemuskulatur. Alternativübungen möglich.

Strengthening of the anterior and rear thighs. Alternative exercises are possible.

Länge/length	1300 mm
Breite/width	1300 mm
Höhe/height	1820 mm
Gewichtspaket/weight stack	2 x 55 kg



## SYGNUM

Plate Loaded

// SYGNUM Plate Loaded ist die Weiterentwicklung des Trainings mit freien Hanteln. Die Geräte werden mit Gewichtsscheiben manuell bestückt. Einige Geräte verfügen über zwei unabhängig voneinander gelagerte Lastarme. Diese ermöglichen ein separates, ausgleichendes Training beider Körperhälften.

// SYGNUM Plate Loaded takes free barbell training a step further. Weight plates are fitted manually to the machines. Some machines have two independently functioning load arms, to allow each side of the body to be trained independently to alleviate any imbalances.



### // Besonderheiten / Features

Training mit Gewichtsscheiben / perfekte Biomechanik / 4 mm Stahlrohre ohne Verschraubung / Rohr-in-Rohr-Verbindung für absolute Stabilität / Individuelle Farbwahl für Polster und Rahmen / Training mit Gewichtsscheiben / perfekte Biomechanik / 4-mm-Stahlrohre ohne Verschraubung / Rohr-in-Rohr-Verbindung für absolute Stabilität / Individuelle Farbwahl für Polster und Rahmen

**00004017 / 00004018**

Rudergerät, 30 mm / 50 mm Plattenaufnahme  
T-Bar-Rowler/Chest, 30 mm / 50 mm Plate Holder

Länge/length	1900 mm
Breite/width	950 mm
Höhe/height	1360 mm

ohne Hantelscheiben / without dumbbell discs

**00004302 / 00004308**

Bankdrückmaschine Dual, 30 mm / 50 mm Plattenaufnahme  
Seated Chest Press Machine Dual, 30 mm / 50 mm Plate Holder

Länge/length	1320 mm
Breite/width	1810 mm
Höhe/height	1770 mm

ohne Hantelscheiben / without dumbbell discs

**00004303 / 00004309**

Schrägbankmaschine Dual, 30 mm / 50 mm Plattenaufnahme  
Incline Bench Press Dual, 30 mm / 50 mm Plate Holder

Länge/length	1580 mm
Breite/width	1850 mm
Höhe/height	1350 mm

ohne Hantelscheiben / without dumbbell discs

**00004304 / 00004310**

Schultermaschine Dual, 30 mm / 50 mm Plattenaufnahme  
Shoulder Press Machine Dual, 30 mm / 50 mm Plate Holder

Länge/length	1210 mm
Breite/width	1830 mm
Höhe/height	1430 mm

ohne Hantelscheiben / without dumbbell discs





**00004305 / 00004311**

Rückenzugmaschine Dual, 30 mm / 50 mm Plattenaufnahme  
Lat Pulley Machine Dual, 30 mm / 50 mm Plate Holder

Länge/length	1430 mm
Breite/width	1500 mm
Höhe/height	2210 mm

ohne Hantelscheiben / without dumbbell discs



**00004306 / 00004312**

Rudermaschine Dual, 30 mm / 50 mm Plattenaufnahme  
Seated Rowing Machine Dual, 30 mm / 50 mm Plate Holder

Länge/length	1240 mm
Breite/width	1300 mm
Höhe/height	1180 mm

ohne Hantelscheiben / without dumbbell discs



Rumpf / Trunk

NOTIZEN / NOTES



**00004301 / 00004307**

Bauchmuskelbank, 30 mm / 50 mm Plattenaufnahme  
Lying Abdominal Bench, 30 mm / 50 mm Plate Holder

Länge/length	1540 mm
Breite/width	1200 mm
Höhe/height	980 mm

ohne Hantelscheiben / without dumbbell discs



Notes section with horizontal lines for writing. Ends with //



**00004022 / 00004023**

Beinpresse 45°, 30 mm / 50 mm Plattenaufnahme  
45° Leg Press, 30 mm / 50 mm Plate Holder

Länge/length 1150 mm

Breite/width 1020 mm

Höhe/height 1430 mm

ohne Hantelscheiben / without dumbbell discs

**00004025 / 00004026**

Wadengerät, 30mm / 50 mm Plattenaufnahme  
Seated Calf Raise, 30 mm / 50 mm Plate Holder

Länge/length 1400 mm

Breite/width 750 mm

Höhe/height 980 mm

ohne Hantelscheiben / without dumbbell discs

**00004037 / 00004038**

Kniebeugenmaschine, 30 mm / 50 mm Plattenaufnahme  
Squat Machine, 30 mm / 50 mm Plate Holder

Länge/length 1720 mm

Breite/width 1250 mm

Höhe/height 1760 mm

ohne Hantelscheiben / without dumbbell discs



NOTIZEN / NOTES

//



**00004313 / 0004314**

Beinpresse Dual, 30 mm / 50 mm Plattenaufnahme  
Leg Press Dual, 30 mm / 50 mm Plate Holder

Länge/length	1240 mm
Breite/width	1300 mm
Höhe/height	1180 mm

ohne Hantelscheiben / without dumbbell discs

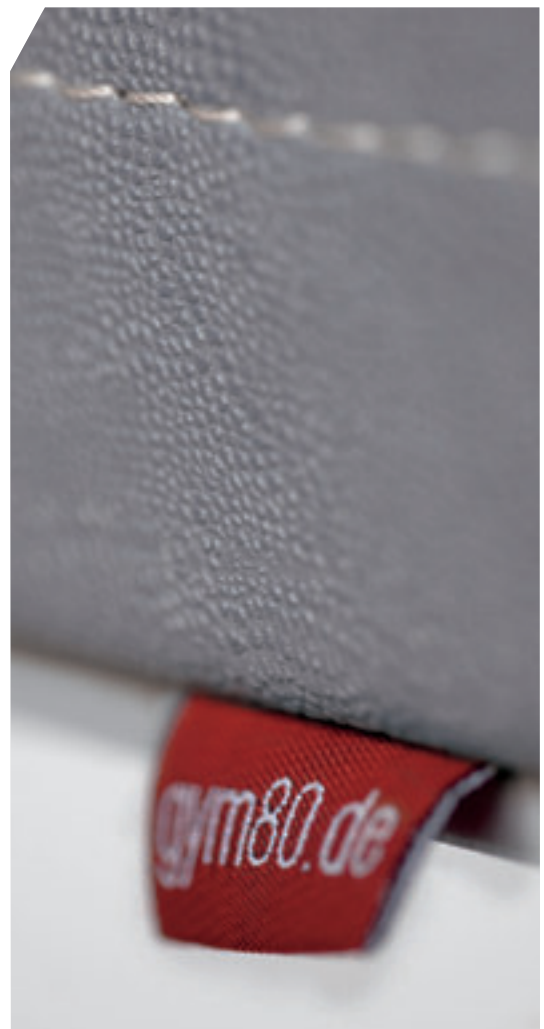



## SYGNUM Functional

// SYGNUM Functional bietet funktionelles Krafttraining. Nicht nur eine, sondern viele verschiedene Muskelgruppen werden während des Trainings dynamisch oder statisch beansprucht und für ihre alltäglichen Funktionen trainiert. Zusätzlich zur Kraftsteigerung wird die Beweglichkeit gefördert sowie die Koordination verbessert. Jede Maschine der Functional Linie bietet eine Fülle von Trainingsvarianten für alle Trainierenden – vom Einsteiger bis zum Leistungssportler.

// Functional offers functional strength training. The exercises target many different muscle groups dynamically or statically, helping to improve their everyday function. As well as increasing strength, they promote mobility and improve coordination. Each machine of the Functional line offers a wide range of alternatives to meet the needs of all users – from beginners to professional athletes.

## // Besonderheiten / Features

Zwei Gewichtsblöcke / Funktionelles Training / Perfekte Biomechanik / Individuelle Farbwahl für Rahmen und Gewichtsverkleidung / Auf Anfrage erhöhte Gewichtspakete / Two weight stacks / Functional training / Perfect biomechanics / Individual selection of colors for frames and weight coverings / Upgrade weight stack on request



### 00004401

Liftmaschine  
Lift Machine

Länge/length	1200 mm
Breite/width	1900 mm
Höhe/height	1600 mm
Gewichtspaket/weight stack	2 x 105 kg



### 00004402

Streck-Press-Maschine  
Incline Machine

Länge/length	1500 mm
Breite/width	1960 mm
Höhe/height	1600 mm
Gewichtspaket/weight stack	2 x 105 kg



### 00004403

Push/Pull Maschine  
Push/Pull Machine

Länge/length	1450 mm
Breite/width	1900 mm
Höhe/height	1580 mm
Gewichtspaket/weight stack	2 x 105 kg



## SYGNUM Basic

// Die SYGNUM Basic Linie ermöglicht ein gezieltes, isoliertes Muskeltraining. Die Muskeln können hierdurch optimal definiert werden. Die klassischen SYGNUM Basic Geräte, wie z. B. Bänke, Freihanteln, Kniebeugenständer, Klimmzugstange oder Bauchmuskelsitz, sind die ideale Ergänzung für ein umfassendes Krafttraining.

// The SYGNUM Basic line is designed for targeted, isolated muscle training, to promote optimal muscle definition. Classic SYGNUM machines, such as benches, barbells, squat racks, pull-up bars and roman chairs, are the ideal complement for all-round strength training.



#### // Besonderheiten / Features

Perfekte Biomechanik / 4 mm Stahlrohre ohne Verschraubung / Individuelle Farbwahl für Polster, Rahmen / Different machines for the same muscle groups / Perfect biomechanics / 4 mm steel tube without bolts / Individual selection of colors for upholstery, frames

Manchmal hat Isolation auch was Gutes – Isolation also has positive aspects

**00004006**

Negativbank breit (ohne Hantelstangen und -scheiben)  
Decline Bench (without bar and dumbbell discs)

Länge/length	1500 mm
Breite/width	1230 mm
Höhe/height	1160 mm
Gewicht/weight	86 kg

**00004008**

Drückbank breit (ohne Hantelstangen und -scheiben)  
Press Bench (without bar and dumbbell discs)

Länge/length	1210 mm
Breite/width	1260 mm
Höhe/height	1160 mm
Gewicht/weight	80 kg

**00004009**

Schrägbank breit (ohne Hantelstangen und -scheiben)  
Incline Bench (without bar and dumbbell discs)

Länge/length	1600 mm
Breite/width	1260 mm
Höhe/height	1330 mm
Gewicht/weight	84 kg

**00004020**

Scott Curler sitzend (ohne Hantelstangen und -scheiben)  
Sitting Scott Curl (without bar and dumbbell discs)

Länge/length	1050 mm
Breite/width	830 mm
Höhe/height	1150 mm
Gewicht/weight	65 kg



Die Abbildung folgt.  
Sie können den Artikel  
aber selbstverständlich  
schon bestellen.



**00004021**

Barren  
Dipping Bars

Länge/length	970 mm
Breite/width	740 mm
Höhe/height	1260 mm
Gewicht/weight	63kg



**00004047**

Negativbank mit verstellbarem Fußteil  
Decline Bench with bar holders adjustable  
(ohne Hantelstangen und -scheiben / without bar and dumbbell discs)

Länge/length	1500 mm
Breite/width	1230 mm
Höhe/height	1160 mm
Gewicht/weight	86 kg



NOTIZEN / NOTES



Die Abbildung folgt.  
Sie können den Artikel  
aber selbstverständlich  
schon bestellen.



#### 00004054

Klimmzugstange (zur Wandmontage)  
Chinning Bar (for wall mounting)

Länge/length	1280 mm
Breite/width	400 mm
Höhe/height	200 mm
Gewicht/weight	20 kg



#### 00004013

Rückengerät 45°  
45 Degrees Back Extension

Länge/length	1400 mm
Breite/width	700 mm
Höhe/height	890 mm
Gewicht/weight	59 kg



#### Rumpf / Trunk



#### 00004027

Bauchmuskelbank  
Abdominal Bench

Länge/length	1400 mm
Breite/width	690 mm
Höhe/height	1000 mm
Gewicht/weight	80 kg



#### 00004028

Kleiner Bauchmuskelsitz  
Roman Chair

Länge/length	1020mm
Breite/width	810 mm
Höhe/height	610 mm
Gewicht/weight	37 kg





**00004030**

Beinhebergerät  
Abdominal Flexor

Länge/length	980 mm
Breite/width	780 mm
Höhe/height	1540 mm
Gewicht/weight	86 kg



**00004046**

Beinhebergerät mit Armlängen Anpassung  
Abdominal Flexor with adjustable arm

Länge/length	980 mm
Breite/width	780 mm
Höhe/height	1540 mm
Gewicht/weight	86 kg



Untere Extremität / Lower Extremities



**00004024**

Kniebeugenständer (ohne Hantelstangen und -scheiben)  
Squat Rack (without bar and dumbbell discs)

Länge/length	1440 mm
Breite/width	1720 mm
Höhe/height	1780 mm
Gewicht/weight	90 kg



**00004043**

Multi Rack (ohne Hantelstangen und -scheiben)  
Multi Rack (without bar and dumbbell discs)

Länge/length	1500 mm
Breite/width	1350 mm
Höhe/height	1800 mm



**00004001 / 00004002**

Multi-Drückstation, 30 mm / 50 mm Plattenaufnahme  
Multi Press Station, 30 mm / 50 mm Plate Holder  
(ohne Hantelscheiben / without dumbbell discs)

Länge/length	1160 mm
Breite/width	2200 mm
Höhe/height	2030 mm
Gewicht/weight	133 kg

**00004005**

Flachbank  
Flatbench

Länge/length	1110 mm
Breite/width	500 mm
Höhe/height	410 mm
Gewicht/weight	30 kg

**00004010**

Universalbank ohne Fußstütze  
Multi Position Bench without foot rest

Länge/length	1280 mm
Breite/width	680 mm
Höhe/height	440 mm
Gewicht/weight	55 kg

**00004011**

Universalbank mit Fußstütze  
Multi Position Bench with foot rest

Länge/length	1280 mm
Breite/width	680 mm
Höhe/height	440 mm
Gewicht/weight	60 kg





**00004039**

Max Rack 30 mm

**00004040**

Max Rack 50 mm

Länge/length	1850 mm
Breite/width	2200 mm
Höhe/height	2190 mm
Gewicht/weight	300 kg



Die Abbildung folgt.  
Sie können den Artikel  
aber selbstverständlich  
schon bestellen.

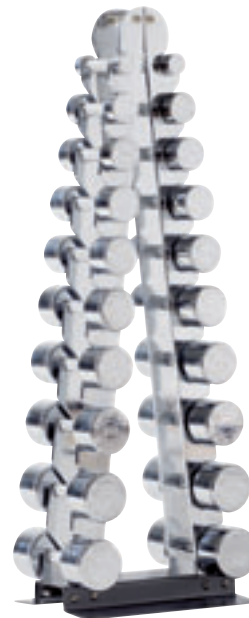

**00004056**

Kurzhandel-Ständer mit 10 gummierten Ablagen  
Dumbbell Rack with 10 rubber holders

Länge/length	1350 mm
Breite/width	510 mm
Höhe/height	720 mm
Gewicht/weight	100 kg



**00004060**

Chromhandelständer inkl. 10 Hantelpaare von 1-10 kg  
Chrome Dumbbell Rack with 10 dumbbells 1-10 kg in pairs

Länge/length	400 mm
Breite/width	600 mm
Höhe/height	1200 mm
Gewicht/weight	120 kg



**00004045**

PRT Progressiver Widerstandstrainer  
(Wandmontage)

Progressiv Resistance Trainer  
(Wallversion)

<u>Länge/length</u>	800 mm
<u>Breite/width</u>	370 mm
<u>Höhe/height</u>	2100 mm
<u>Gewicht/weight</u>	63 kg

**00004048**

PRT Progressiver Widerstandstrainer  
(Standgerät)

Progressiv Resistance Trainer  
(Standversion)

<u>Länge/length</u>	1100 mm
<u>Breite/width</u>	1000 mm
<u>Höhe/height</u>	2100 mm
<u>Gewicht/weight</u>	86 kg



Die Abbildung folgt.  
Sie können den Artikel  
aber selbstverständlich  
schon bestellen.

**00004050**

Kurzhandel-Ständer mit gummierten Ablagen  
Dumbbell Rack with rubber holder

Länge/length	2500 mm
Breite/width	440 mm
Höhe/height	720 mm
Gewicht/weight	100 kg



Die Abbildung folgt.  
Sie können den Artikel  
aber selbstverständlich  
schon bestellen.

**00004051**

Kurzhandel-Ständer ohne gummierte Ablagen  
Dumbbell Rack without rubber holder

Länge/length	2500 mm
Breite/width	440 mm
Höhe/height	720 mm
Gewicht/weight	100 kg



**00004052**

Plattenständer (ohne Hantelscheiben)  
Disc Stand (without discs)

Länge/length	800 mm
Breite/width	580 mm
Höhe/height	1190 mm
Gewicht/weight	17 kg



**00004053**

Langhandel-Ständer (ohne Hantelstange und -scheiben)  
Barbell Rack (without bar and dumbbell dics)

Länge/length	800 mm
Breite/width	910 mm
Höhe/height	1330 mm
Gewicht/weight	75 kg





# Zubehör

## Accessories

// Für Ihre SYGNUM Linien finden Sie hier garantiert das passende Zubehör, wie z. B. Stangen, Griffe, Hanteln und Scheiben. Bei den entsprechenden Geräten sind die Griffe und Stangen einfach per Karabinerhaken austauschbar. So können Sie an ein und demselben Gerät mehrere Übungen machen.

// You're sure of finding the right accessories for your SYGNUM machines here, from bars and handles to dumbbells and discs. The handles and bars of the machines can easily be changed using snap hooks, allowing you to carry out different exercises on the same machine.



#### // Besonderheiten / Features

Stangen und Hantelscheiben mit 30 mm und 50 mm Aufnahme / Griffe in unterschiedlichen Varianten / Hanteln in 1 oder 2,5-kg-Abstufungen / Bars and dumbbell discs with 30 mm and 50 mm weight accommodation / Different handle variants / Dumbbells available in 1 or 2.5 kg increments

Artikel-Nr. order no.	Artikel / item	Länge length (mm)	Breite width (mm)	Höhe height (mm)	Gewicht weight (kg)
00004060	Chromhantelsatz, 1-10 kg paarweise / Chrome Dumbbell Set, 1-10 kg, in pairs	400	600	120	120,00
00004061	Kurzhandtel, gummiert 2,5 kg / Rubber Dumbbell 2.5 kg	300	300	300	2,50
00004062	Kurzhandtel, gummiert 5,0 kg / Rubber Dumbbell 5.0 kg	300	300	300	5,00
00004063	Kurzhandtel, gummiert 7,5 kg / Rubber Dumbbell 7.5 kg	300	300	300	7,50
00004064	Kurzhandtel, gummiert 10,0 kg / Rubber Dumbbell 10.0 kg	300	300	300	10,00
00004065	Kurzhandtel, gummiert 12,5 kg / Rubber Dumbbell 12.5 kg	300	300	300	12,50
00004066	Kurzhandtel, gummiert 15,0 kg / Rubber Dumbbell 15.0 kg	300	300	300	15,00
00004067	Kurzhandtel, gummiert 17,5 kg / Rubber Dumbbell 17.5 kg	300	300	300	17,50
00004068	Kurzhandtel, gummiert 20 kg / Rubber Dumbbell 20 kg	500	500	500	20,00
00004069	Kurzhandtel, gummiert 22,5 kg / Rubber Dumbbell 22.5 kg	500	500	500	22,50
00004070	Kurzhandtel, gummiert 25 kg / Rubber Dumbbell 25 kg	500	500	500	25,00
00004071	Kurzhandtel, gummiert 27,5 kg / Rubber Dumbbell 27.5 kg	500	500	500	27,50
00004072	Kurzhandtel, gummiert 30 kg / Rubber Dumbbell 30 kg	500	500	500	30,00
00004073	Kurzhandtel, gummiert 32,5 kg / Rubber Dumbbell 32.5 kg	500	500	500	32,50
00004074	Kurzhandtel, gummiert 35 kg / Rubber Dumbbell 35 kg	500	500	500	35,00
00004075	Kurzhandtel, gummiert 37,5 kg / Rubber Dumbbell 37.5 kg	500	500	500	37,50
00004076	Kurzhandtel, gummiert 40 kg / Rubber Dumbbell 40 kg	500	500	500	40,00
00004077	Kurzhandtel, gummiert 42,5 kg / Rubber Dumbbell 42.5 kg	500	500	500	42,50
00004078	Kurzhandtel, gummiert 45 kg / Rubber Dumbbell 45 kg	500	500	500	45,00
00004079	Kurzhandtel, gummiert 47,5 kg / Rubber Dumbbell 47.5 kg	500	500	500	47,50
00004080	Kurzhandtel, gummiert 50 kg / Rubber Dumbbell 50 kg	500	500	500	50,00
00004081	Kurzhandtel, gummiert 52,5 kg / Rubber Dumbbell 52.5 kg	500	500	500	52,50
00004082	Kurzhandtel, gummiert 55 kg / Rubber Dumbbell 55 kg	500	500	500	55,00
00004083	Kurzhandtel, gummiert 57,5 kg / Rubber Dumbbell 57.5 kg	500	500	500	57,50
00004084	Kurzhandtel, gummiert 60 kg / Rubber Dumbbell 60 kg	500	500	500	60,00
00004087	Kurzhandtelsatz, gummiert 2,5-25 kg / Rubber Dumbbell Set 2.5-25 kg				275,00
00004088	Kurzhandtelsatz, gummiert 27,5-50 kg / Rubber Dumbbell Set 27.5-50 kg				775,00
00004231	Gummierte Hantelscheibe 30 mm 1,25 kg / Rubber Disc 30 mm 1.25 kg	300	300	300	1,25
00004232	Gummierte Hantelscheibe 30 mm 2,5 kg / Rubber Disc 30 mm 2.5 kg	300	300	300	2,50
00004233	Gummierte Hantelscheibe 30 mm 5 kg / Rubber Disc 30 mm 5 kg	300	300	300	5,00
00004234	Gummierte Hantelscheibe 30 mm 10 kg / Rubber Disc 30 mm 10 kg	300	300	300	10,00
00004235	Gummierte Hantelscheibe 30 mm 15 kg / Rubber Disc 30 mm 15 kg	300	300	300	15,00
00004236	Gummierte Hantelscheibe 30 mm 20 kg / Rubber Disc 30 mm 20 kg	500	500	500	20,00
00004237	Gummierte Hantelscheibe 30 mm 25 kg / Rubber Disc 30 mm 25 kg	500	500	500	25,00
00004251	Gummierte Hantelscheibe 50 mm 1,25 kg / Rubber Disc 50 mm 1.25 kg	300	300	300	1,25
00004252	Gummierte Hantelscheibe 50 mm 2,5 kg / Rubber Disc 50 mm 2.5 kg	300	300	300	2,50
00004253	Gummierte Hantelscheibe 50 mm 5 kg / Rubber Disc 50 mm 5 kg	300	300	300	5,00
00004254	Gummierte Hantelscheibe 50 mm 10 kg / Rubber Disc 50 mm 10 kg	300	300	300	10,00
00004255	Gummierte Hantelscheibe 50 mm 15 kg Rubber Disc 50 mm 15 kg / handle grip	500	500	500	15,00
00004256	Gummierte Hantelscheibe 50 mm 20 kg Rubber Disc 50 mm 20 kg / handle grip	500	500	500	20,00
00004257	Gummierte Hantelscheibe 50 mm 25 kg / Rubber Disc 50 mm 25 kg	500	500	500	25,00

Artikel-Nr. order no.	Artikel / item	Länge length (mm)	Breite width (mm)	Höhe height (mm)	Gewicht weight (kg)
00002100	Olympiahantel 50 mm, 2200 mm lang / Olympic Bar 50 mm 2200 mm long	2200	100	100	21,50
00002101	Trainingshantel 50 mm, 2200 mm lang / Training Bar 50 mm 2200 mm long	2200	100	100	19,00
00002102	Trainingshantel 30 mm, 2200 mm lang / Training Bar 30 mm 2200 mm long	2200	100	100	12,50
00002103	Trainingshantel 30 mm, 1600 mm lang / Training Bar 30 mm 1600 mm long	1600	100	100	9,00
00002104	SZ Stange 47° 30 mm / EZ Bar 30 mm	1600	150	150	7,50
00002105	SZ Stange-Olympia 50 mm / EZ Bar 50 mm	1600	150	150	8,00
00002106	Stellring 50 mm (Paar) / Olympic collars 50 mm (pair)	100	100	100	
00002107	Federstellring 30 mm (Paar) / Spring collars 30 mm (pair)				
00002108	Stellring 50 mm (Paar) / Collars 50 mm (pair)				
00002131	Federstellring 50 mm (Paar) / Spring collars 50 mm (pair)	100	100	100	
00002135	Trainingshantel 50 mm, 1600 lang / Training Bar 50 mm 1600 mm long	1600	100	100	
00002136	Trainingshantel 50 mm , 1850 lang / Training Bar 50 mm 1850 mm long	1800	100	100	16,50

NOTIZEN / NOTES





**00002009** Leder-Fußschlaufe / Leather Ankle Strap **00002010** Latzugszange mit Gummigriff / Lat Bar **00002111** Latzugstange, parallel 24° / Parallel Palms Bar **00002112** Trizepsgriff, gerade / Straight Triceps Press **00002113** Trizepsgriff, gebogen / EZ Triceps Bar **00002121** Parallelgriff (hoch) / parallel handle **00002123** V-Trizepsgriff / V-Triceps handle **00002124** Doppel„O“-Griff / O Grip Bar **00002127** Trizeps „V“-Stange 12“ / Alternative V-Press **00002128** Parallel-Trizeps-Stange 10“ / V-Press with end stops **00002132** Trizepsseil / Tricep rope **00002151** Triangelgriff leicht / Stirrup Handle **00002152** Long-Pulley-Griff / Long Pulley Handle **00002153** Triangelgriff mit Band (Cable ART lang) / Stirrup Handle with long straps **00002154** Gummifußschlaufe für cable Art / Stirrup Handle with long straps **00002315** Textil-Fußschlaufe Cable Art 5106 / Textil Strap for Cable Art **06002111** Triangelgriff mit Band, Cable Art kurz / Stirrup Handle light

NOTIZEN / NOTES

//





## Design & Farbe

### Design and Colour

// Zu einem perfekt abgestimmten Gerätekonzept gehört auch ein perfektes Design. Bei unseren Maschinen können Sie zwischen zahlreichen Polsterfarben, Rahmenlackierungen und Gewichtsverkleidungen wählen. Auch darüber hinaus kommen wir all Ihren Wünschen gerne nach. Egal ob es um Sonderfarben oder die Bestickung mit Ihrem Logo geht. Passen Sie unsere Geräte Ihrer Einrichtung und Ihrem Corporate Design an und damit dem individuellen Erscheinungsbild Ihres Studios.

// Perfect design is an essential component of a perfectly harmonized machine concept. Our machines can be supplied with a wide selection of upholstery colors, frame paints and weight coverings. We will also be pleased to cater to your individual requirements - from special colors to the embroidering of your logo. Tailor our machines to your facility and corporate design to create an individual image for your fitness center.

### Rahmenlackierung / Frame Paintwork (Standardfarben / standard colours)

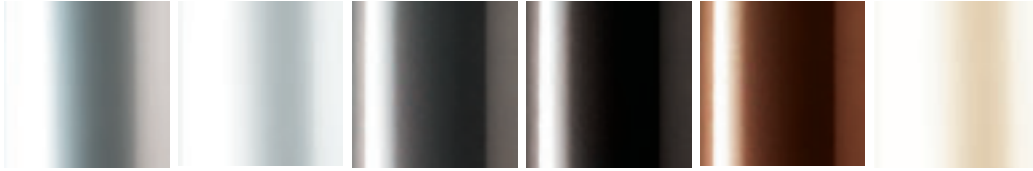

Silber / silver    Weiß / white    Anthrazit / granite    Schwarz / black    Braun / brown    Champagner / champagne

### Gewichtsverkleidung (Standardfarben / standard colours)

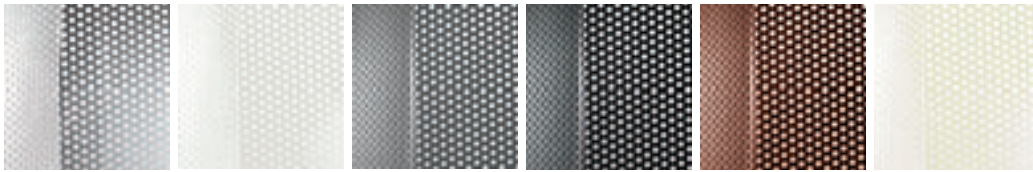

Silber / silver    Weiß / white    Anthrazit / granite    Schwarz / black    Braun / brown    Champagner / champagne

### Polsterfarben / Upholstery Color (Standardfarben / standard colours)



Weiß / white    Schiefer / schist    Beige / beige    Gelb / yellow    Lima / lima    Terracotta / terracotta



Feuer / fire    Mohn / poppy    Rubin / rubin    Braun / brown    Dunkelraun / darkbrown    Schwarz / black



Limone / lemon    Avocado / avocado    Agave / agave    Atoll / atoll    Granit / granit

### Individuelle Bestickungen / Stitching



Formgenähte Polster und Bestickungen gegen Aufpreis / Formsewed upholstery and stitching at an extra charge

# circular

// circular ist der perfekte Trainingseinstieg für Jugendliche, Senioren, Einsteiger und Fortgeschrittene. Der Power Zirkel bietet ein ideales Ganzkörper-Workout. Durch neun serienmäßige, aufeinander abgestimmte Geräte mit nahezu stufenlos verstellbaren Hydraulikzylindern bietet dieser Zirkel insgesamt 16 Übungen. Mit zwei optional erhältlichen circular Geräten lassen sich die Trainingsmöglichkeiten sogar auf 18 Übungen erweitern.

// circular is the perfect introductory training for young people, senior citizens, beginners and advanced users. The Power Circle provides the perfect whole-body workout. Nine standard and perfectly complementary machines equipped with adjustable hydraulic cylinders provide a total of 16 exercises. Two optional circular machines increase the training options to 18 exercises.

## // Besonderheiten / Features

Nur knapp 20 Minuten für eine Trainingsrunde / Stärkung von Muskeln, Herz-Kreislauf-System, Ausdauer, Knochenstruktur / Nahezu stufenlos verstellbare Hydraulikzylinder für gelenkschonendes Training / Rollen an den Geräteunterseiten für mühelosen Transport / One training round takes less than 20 minutes / Strengthens muscles, the cardiovascular system, endurance and bone structure / Hydraulic cylinders with nearly infinite settings for training that is especially easy on the joints / Rollers mounted to the undersides of the devices ensure easy transport



Ein Kreis. Ein Rhythmus.

One circle. One rhythm.



**00003054**

Bizeps- und Trizepsmaschine  
Arm Curl and Triceps Extension Machine

Länge/length	840 mm
Breite/width	780 mm
Höhe/height	100 mm
Gewicht/weight	32 kg

**00003051**

Bankdrück- und Rudermaschine  
Chest Press and Rowing Machine

Länge/length	1200 mm
Breite/width	840 mm
Höhe/height	1120 mm
Gewicht/weight	59 kg

**00003052**

Brust- und Rückenmaschine  
Butterfly and Rear Delt Machine

Länge/length	800 mm
Breite/width	660 mm
Höhe/height	1000 mm
Gewicht/weight	68 kg





**00003053**

Schulter- und Rückenzugmaschine  
Shoulder Press and Lat Pulley Machine

Länge/length	900 mm
Breite/width	1160 mm
Höhe/height	1330 mm
Gewicht/weight	59 kg



Rumpf / Trunk



**00003055**

Bauchmuskelmaschine und Rückenstrecker  
Abdominal and Lower Back Machine

Länge/length	1100 mm
Breite/width	770 mm
Höhe/height	1300 mm
Gewicht/weight	41 kg



**00003059**

Twister

Länge/length	1100 mm
Breite/width	900 mm
Höhe/height	1050 mm
Gewicht/weight	59 kg





**00003056**

Beinbeuger und Beinstrecker  
Seated Leg Curl and Leg Extension Machine

Länge/length	1100 mm
Breite/width	800 mm
Höhe/height	1000 mm
Gewicht/weight	68 kg

**00003057**

Ab- und Adduktionsmaschine  
Ab- and Adductionsmaschine

Länge/length	1200 mm
Breite/width	790 mm
Höhe/height	1000 mm
Gewicht/weight	59 kg

**00003058**

Beinpresse  
Leg Press

Länge/length	1800 mm
Breite/width	700 mm
Höhe/height	1140 mm
Gewicht/weight	59 kg





**00003060**

Stepper

Länge/length 1100 mm  
Breite/width 660 mm  
Höhe/height 1350 mm  
Gewicht/weight 68 kg



**00003062**

Kniebeugenmaschine  
 Seated Saftey Squat

Länge/length 1620 mm  
Breite/width 700 mm  
Höhe/height 1600 mm  
Gewicht/weight 120 kg



NOTIZEN / NOTES

---



---



---



---



---



---



---



---



---



---

## enforbike®

The logo for enforbike® features the brand name in a dark blue, sans-serif font. Below the text, there are three horizontal, wavy lines that sweep from left to right, creating a sense of motion or a stylized representation of a bike's frame or wheels.

// Das enforbike® ist ein einzigartiges Impuls-Radergometriesystem für die Bereiche Fitness, Rehabilitation und Prävention. Es bietet eine spezielle Kombination von Cardio- und Impulstraining. Das Novum des enforbike® ist eine mechanisch entkoppelte, impulsbeaufschlagte Tretlagereinheit (an den Pedalen). Der Impuls geht ausschließlich in die Senkrechte des Tretlagers, wodurch verstärkt die unteren Extremitäten angesprochen werden. Das lokale Impulstraining unter dynamischer Belastung regt die Muskeln in den unteren Extremitäten gezielt zur Mehrarbeit an.

// The enforbike® is a unique impulse cycling ergonomic system for fitness, rehabilitation and prevention. It offers a special combination of cardio and impulse training. The innovative feature of the enforbike® is a mechanically decoupled, impulse-loaded bracket unit (on the pedals). The impulse travels vertically in the bracket unit, placing greater demand on the lower extremities. Local impulse training under dynamic load specifically targets the muscles of the lower extremities, making them work harder.

## // Besonderheiten / Features

Herz-Kreislauf-System wird trainiert und der Stoffwechsel gefördert / Deutlicher Kalorienmehrerbrauch / Steigert Kraft und Ausdauer / Fördert die Koordinationsfähigkeit / Gelenkschonende Bewegungsabläufe / Trains the cardiovascular system and boosts the metabolism / Significant increase in calorie consumption / Boosts strength and endurance / Promotes coordination / Motion sequences designed to protect the joints

00001710 enforbike 



NOTIZEN / NOTES

//

## SOFTWARE

by gym80 International

// Die gym80-Software, die wir gemeinsam mit der Firma aktivKONZEPTE AG entwickelt haben, bietet ein umfangreiches Trainings-, Dokumentations- und Managementsystem. Die Software unterstützt Therapeuten und Patienten gleichermaßen. Die gym80-Software gibt es in den Abstufungen Home (Trainingsplan-Erstellung für Einzelanwender, die aus einem Gesamtkatalog Übungen auswählen), Standard (eigenhändige Trainingsplan-Erstellung und Verwaltung der Ergebnisse), Professional (hier werden Trainingsvorgaben über das Terminal erteilt und Ergebnisse eingepflegt) und die Komplettlösung Enterprise, bei der zusätzlich an den Geräten ein WorkoutPoint durch die Übung führt und die Ergebnisse automatisch speichert und dokumentiert. Die gym80-Software entlastet Sie so in Ihrer täglichen Arbeit und hilft Ihnen, Ihren Trainingsbetrieb noch profitabler zu gestalten.

// gym80 software, developed in partnership with aktivKONZEPTE AG, is a comprehensive training, documentation and management system. The software supports therapists and patients alike. gym80 software is available in the levels Home (training plans for individual users who select exercises from a comprehensive catalog), Standard (personal creation of training plans and management of results), Professional (training specifications are defined via the terminal and the results maintained) and the Enterprise complete solution, where a WorkoutPoint at the machine guides the user through the exercise and automatically saves and documents the results. The gym80 software lightens your daily workload and helps you to boost the profitability of your training facility.



#### // Besonderheiten / Features

Für jede Einrichtung das passende System / Support, Service etc. ab Software Standard / Upgrades der Software auf die nächsthöheren Versionen jederzeit möglich / The right system for each facility / Support, service etc. available for the Standard software version and higher / Software upgrades to higher level versions are possible at any time

## ServicePoint

Text, Bild, Video: Der ServicePoint ist für den Studio- bzw. Praxisbesucher das Eingangstor zu einer neuen Trainingswelt. Hier kann sich der Trainierende selbstständig und aktuell über seine Trainingsergebnisse, die Leistungsentwicklung und selbstverständlich auch über seine aktuellen Trainingspläne informieren. Einmal registriert, sind alle persönlichen Informationen sofort abrufbar.

Text, images, and video: ServicePoint is the gateway to a new world of training for fitness enthusiasts and medical patients. It gives end users the ability to look up their training results, see how much they have improved, and even access their current training plans. Once they have registered they can immediately access their personal information at any time. ServicePoint offers an integrated messaging system that allows users to exchange messages and receive the latest information from trainers, fitness studio, or physiotherapists.



## TrainerPoint

Die Zentrale der neuen Software heißt TrainerPoint. Hier werden alle Kundendaten verwaltet, individuelle Trainingspläne und Leistungstests erstellt. Trainingszielsetzung und Fortschritte werden permanent dokumentiert und können vom Trainer oder Therapeuten jederzeit kontrolliert werden. Der detaillierte Einblick in das individuelle Trainingsarchiv jedes einzelnen Mitglieds bietet eine großartige Hilfestellung, um Mitglieder erfolgreich zu betreuen. Viele weitere Analysemöglichkeiten aus den insgesamt erhobenen Daten geben zudem die Möglichkeit, Aussagen über den gesamten Trainingsbetrieb zu machen: Welche Geräte werden wie oft genutzt? Wann ist Rush-Hour, wann Ruhe vor dem Sturm? Wann müsste für Kinderbetreuung gesorgt werden? Der TrainerPoint versorgt Studiobetreiber, Therapeuten oder Hotelleitung mit Antworten auf alle Fragen.

TrainerPoint is the control unit of gym80's new software. It administers all customer data and creates customized training plans and performance tests. Training goals and progress are permanently recorded and can be checked at any time by the trainer or therapist. The detailed insight into each studio member's customized training archive is a huge help for their successful

assistance. Multiple additional options for the analysis of stored data also give the opportunity to make statements about the entire training studio. TrainerPoint provides studio owners, therapists and hotel managers the answers to the following questions: Which machines are used how often? When is the facility being used at capacity? When should we provide child care services?



## WorkoutPoint

Kleincomputer an jedem Gerät begleiten den Studio- bzw. Praxisbesucher durch sein Training: die WorkoutPoints. Hier wird der Kunde mit allen wichtigen Informationen versorgt: Individuelle Sitzhöhe, Anzahl der Wiederholungen, Höhe der Belastung und vieles mehr. Beim Einsatz in der Physiopraxis lassen sich hier wichtige Messungen für die Erstellung eines optimalen Reha-Plans vornehmen. Während des Workouts dienen die Monitore der optimalen Bewegungskontrolle. Ist der Rhythmus korrekt? Ist die Streckung vollständig? Nur wer hier besteht, wird zum nächsten Gerät geleitet.

Small computers, called WorkoutPoints, in each machine walk the studio member or medical patient through their training session. They supply the user with all important information, such as customized seat height, number of repetitions, exertion level, and more. When used in physiotherapy, it can perform important measurements for the creation of an optimized rehabilitation plan. The monitors provide optimal movement control during the workout. Is the rhythm correct? Are the movements fully extended? Once you have passed on this machine, you can move on to the next one.

## ForcePoint

Eine exakte Kraftmessung erleichtert die Erstellung individuell zugeschnittener Trainingspläne. Mit dem ForcePoint schafft die Software-Version 2.0 nun auch in diesem Bereich optimale Voraussetzungen. Ab sofort ist an jedem Trainingsgerät eine individuelle Kraftmessung möglich, die parallel zum dynamischen Training aufgezeichnet wird. So lassen sich aktuelle Kraftentwick-



## MobilePoint

lungen noch während des Verlaufs der Geräteübung dokumentieren. Der ForcePoint ermöglicht darüber hinaus auch ein statisches Krafttraining, bei dem Übungen beispielsweise mit vorgegebenem, exakt dosierten Kräfteinsatz absolviert werden.

Exact strength measurements make it easier to create customized training plans. Version 2.0 of the software now provides the optimal prerequisites in this area as well with ForcePoint. You can now perform a customized strength measurement, which is recorded along with the dynamic training, on every machine. This allows you to document the strength level at which you are performing. ForcePoint also enables static strength training in which exercises are performed with a predetermined, precisely prescribed use of strength.

Trainer und Therapeuten sollten überall in der Einrichtung über das aktuelle Geschehen im Bilde sein. Mit dem MobilePoint der Version 2.0 wurde die Software um dieses wertvolle und hilfreiche Feature erweitert. Mit dem PDA ist der Trainer oder Therapeut nicht nur ständig und an jedem Ort per Alarmfunktion erreichbar, sondern darüber hinaus in der Lage, auftretende Probleme bei einzelnen Trainierenden sofort zu erkennen, da er alle Daten in Echtzeit empfangen kann.

Trainers and therapists should always be aware of what is going on in their facilities. Version 2.0 of the software includes this valuable and helpful feature called MobilePoint. The alarm tool ensures the trainer or therapist can be reached at any time and anywhere in the studio via PDA. It also ensures that they are able to immediately recognize problems as they occur with each user since the access data in real time.

## ExercisePoint

Ein optimales Training für den ganzen Körper schließt geräteunabhängige Übungen ein. Am ExercisePoint der Version 2.0 sind nun zum Beispiel auch Dehnübungen sowie Übungen mit dem Theraband oder Hanteln in die Software eingebunden. Nach dem Einloggen stehen dem Trainierenden zwei Varianten zur Verfügung: Beim geführten Workout demonstriert ein virtuelles Model auf dem Monitor die exakte Bewegungsausführung, während der Trainierende die Übung real in gleichem Rhythmus und Umfang ausführt. Beim ungeführten Training lässt sich der Trainierende die Übung im Vorfeld detailliert per Bild, Video oder Text vorstellen und führt sie dann eigenständig abseits des ExercisePoint durch.

Optimum training for the entire body includes exercises that do not rely on exercise equipment. Version 2.0 of ExercisePoint features stretching exercises, as well as, exercises using resistance bands and dumbbells. After logging in, the user can choose one of two workout modes. In the guided workout, a virtual model demonstrates the exact movement on the screen while the user performs the exercise using the same rhythm and range in real life. In the unguided workout, the user learns all details of the exercise beforehand using pictures, video or text and then performs it on his own aside from the ExercisePoint.



## NOTIZEN / NOTES

---



---



---



---



---



---



---



---



---



---

## // gym80-Software Home

Die Home-Variante der gym80-Software wendet sich in erster Linie an Einzelanwender oder Trainer, die neue Anregungen bei der Erstellung von Übungsplänen suchen. Mit dem System lassen sich perfekte Trainingspläne erstellen und ausdrucken. Dazu wählt der Benutzer die Übungen aus einem umfangreichen Gesamtkatalog aus und stellt sie in die gewünschte Reihenfolge. Die gym80-Software Home ist ein reines Einzelplatz-Programm und keine Client-Server-Anwendung.

The Home version of our gym80-Software appeals primarily to individual users or trainers who are looking for new ideas for creating exercise plans. The system allows creating and printing out perfect training plans. Simply select the exercises from a comprehensive exercise catalog and arrange them in the desired order. The Home version of the gym80-Software is a single-license program and not a client-server application.

## // gym80-Software Standard

Die Standard-Variante der gym80-Software bietet höchsten Komfort bei der Erstellung von Trainingsplänen und der Verwaltung von Ergebnissen. Hier rückt der Trainer verstärkt in den Mittelpunkt. Er ist es, der dem Trainierenden die Pläne und Vorgaben als Ausdruck an die Hand gibt. Und der Trainer ist es auch, der die Übungsergebnisse im Anschluss in die Datenbank der Software einpflegt. Das Standard-System verfügt weder über Mini-PCs noch über Terminals auf der Trainingsfläche. Der Trainierende greift selbst nicht in das Programm ein.

The Standard version of our gym80-Software offers you comfort and convenience in the creation of training plans and the administration of results. The focus is entirely on the trainer. The trainer is the one who hands the plans and instructions as printout to the user, and it's also the trainer who enters the exercise results into the software. The Standard version does not include mini-PCs or terminals on the floor, and end users do not have access to the program.



## // gym80-Software Professional

In der Professional-Version kommt die gym80-Software ohne Mini-PCs und damit auch ohne Online-Monitoring aus. Die Übungsvorgaben erhält der Trainierende nicht unmittelbar am jeweiligen Gerät, sondern über Terminals, die auf der Trainingsfläche der Anlage platziert werden. Hier werden nach der Übung auch die Trainingsergebnisse in die Software eingepflegt. Anders als in der Enterprise-Variante geschieht dies manuell und nicht automatisch. Alle weiteren Features der gym80-Software sind in der Professional-Version enthalten.

The Professional version of the gym80-Software neither includes mini-PCs and therefore nor the OnlineMonitoring feature. This version of the gym80-Software allows users to receive exercise instruction on free-standing terminals and not directly on the equipment. Other than at the Enterprise version, the exercise results are entered manually into the software at the free-standing terminals. The Professional version includes all the other gym80-Software features.

**Mit gym80 International beginnt das Training der Zukunft schon heute.**

**Today gym80 International is shaping the way people will exercise in the future.**

## // gym80-Software Enterprise

Diese Komplett-Lösung kann einfach alles: Übungen demonstrieren, Kundenlisten organisieren und Trainingsergebnisse dokumentieren. Die gym80-Software Enterprise verfügt über eine zentrale Datenbank, aus der die individuellen Trainingspläne sowie detaillierte Trainingsvorgaben bis hin zum Rhythmus der Bewegung mit einem Klick abrufbar sind. Alle Trainingsgeräte sind mit einem vollwertigen Mini-PC ausgestattet und miteinander vernetzt. Die gesammelten Trainingsdaten werden automatisch erfasst, eingepflegt und gespeichert. Die gym80-Software Enterprise besteht aus ServicePoint, TrainerPoint, und WorkoutPoint und kann nach Wunsch um ExercisePoint, MobilePoint und ForcePoint erweitert werden. Trainer und Studio-Betreiber haben außerdem die Möglichkeit, mit dem Online-Monitoring einen Überblick über den aktuellen Trainingsbetrieb zu bekommen.

This end-to-end solution does it all: demonstrate exercises, organize customer lists and document training results. The gym80 Enterprise software has a centralized database that delivers customized training plans and detailed training instructions including the rhythm of the movement with a simple click. All of the exercise machines are equipped with a full-value mini-PC and are networked together. The gathered training data is automatically compiled, entered and saved. gym80 Enterprise software includes the ServicePoint, TrainerPoint, and WorkoutPoint features and can be expanded upon request to include ExercisePoint, MobilePoint, and ForcePoint. Trainers and studio owners also have the option of maintaining an overview of all activities in the studio with the Online-Monitoring feature.

## // Neue Features mit der gym80-Software 3.0

Jetzt vormerken und bestellen und ab MEDICA 2010 nutzen / Note now, order and use starting from MEDICA 2010

### GroupPoint

Planung, Buchung und Dokumentation von GroupFitness-Aktivitäten (z. B.: Aerobic, Taebo, ...).  
Planning, booking and documentation of GroupFitness-activities (e.g.: Aerobic, Taebo, ...)

- Kunde kann sich über Kurs und Trainer informieren und selbständig anmelden
- Trainer wiederum hat immer den aktuellen Teilnehmerüberblick.
- Kunde kann sich über den WebPoint dann auch von zu Hause oder von der Arbeit über die Kurse informieren und anmelden.
- Customer can read up on courses, trainers and apply by himself
- Trainer has always an up-to-date overview of the participants
- Customer can read up on courses and apply by himself from home or work on the WebPoint

### ManagerPoint

Multistudiofähigkeit / Multistudio ability

- Kunde kann in mehreren Studios einer Kette trainieren
- Trainingspläne werden nach den jeweils verfügbaren Übungen angepasst
- Übergreifendes Managementtool erlaubt dem Betreiber der Kette studioübergreifende Statistiken
- Customer can train at different studios of a studio chain
- Training plans are adapted to available exercises
- Overlapping Management-tool allows operators to keep overlapping studio statistics

### WebPoint

Internetzugriff auf Funktionalitäten der UserPoints (ServicePoint, GroupPoint, OutdoorPoint)  
Internet access to functionalities of the UserPoint (ServicePoint, GroupPoint, OutdoorPoint)

- Kunde kann via Internetbrowser von außen auf ServicePoint zugreifen
- Kunde kann sich bei gleichzeitigem Betrieb des GroupPoint über Kurse informieren und anmelden
- Kunde kann sich bei gleichzeitigem Betrieb des OutdoorPoint über seine Outdoor-Aktivitäten informieren
- Customer can access the ServicePoint via internet browser from the outside
- Customer can read up on and apply for courses while the GroupPoint is working
- Customer can read up on his outdoor-activities while the OutdoorPoint is working

### OutdoorPoint

Planung und Dokumentation von Outdoor-Aktivitäten  
Planning and documentation of outdoor-activities

- Inkl. Import von ausgewählten Herzfrequenzuhren
- Bindung von auch außerhalb des Studios aktiven Kunden
- Import of selected heart frequencies included
- Linking of customers who are active outside of the studio included

### InfoPoint

Eigenständiges Zusammenstellen von Übungsabfolgen durch das Mitglied  
Independent compile of exercise sequences through the studio member

- Benutzersteuerung wie am ServicePoint
- Trainingsplangestaltung ohne zusätzlichen Trainereingriff
- User control like as the ServicePoint
- Setting of training plan without extra intervention of a trainer

### BrainPoint

Erweiterung der WorkoutPoint Funktionalität / Enlargement of WorkoutPoint functionality

- Training der geistigen Vitalität
- In der Trainingspause werden Denkspiele absolviert werden können
- Training of mind vitality
- Brain teasers during training breaks

### CirclePoint

Erweiterung der GroupPoint Funktionalität / Enlargement of GroupPoint functionality

- WorkoutPoint gesteuertes Gruppensitzeltraining welches über den GroupPoint geplant und gebucht werden kann
- circular group training which can be planned and booked at the GroupPoint



// Wir lieben es, Sie täglich aufs Neue zu inspirieren.  
Testen Sie unsere neue Software 3.0 und lassen Sie sich von ihren vielfältigen Vorzügen überzeugen.

// We love inspiring you to try something new every day.  
Test our new software 3.0 and see our numerous advantages for yourself

## gym80-Software

### Produkte / Products

#### Basis-Module / Base modules

- ServerPoint
- TrainerPoint
- ServicePoint
- WorkoutPoint
- ExercisePoint
- MobilePoint
- ForcePoint

#### Erweiterungs-Module / Add-on modules

ab der Version 3.0 / starting with version 3.0

- GroupPoint
- ManagerPoint
- WebPoint
- OutdoorPoint
- InfoPoint
- BrainPoint
- CirclePoint

### Technische Daten / Technical Data

Windows-Netzwerk / Windows network  
MySQL-Datenbank / MySQL database

#### WorkoutPoint

##### Ausstattung / system configuration:

Windows-CE-basierter Mini-PC /  
Windows CE-based Mini-PC

8"-TFT-Touchscreen-Display  
8" TFT touch screen display

Sensor zur Bewegungsmessung / movement sensor

#### TrainerPoint & ServicePoint

Programmiert für Windows XP  
auf einem Multimedia-PC  
Programmed for Windows XP  
on a multimedia PC

PC-Hardware ist nicht inbegriffen  
PC hardware not included

Software 3.0	gym80 Software Enterprise	UPGRADE Enterprise	gym80 Software Professional	UPGRADE Professional	gym80 Software Standard	UPGRADE Standard	gym80 Software Home
Benötigte Rechner	min. 1		min. 1		min.1		min. 1
ServerPoint	ja / yes		ja / yes		ja / yes		nein / no
TrainerPoint	ja / yes		ja / yes		ja / yes		nein / no
ServicePoint*	optional		optional		nein / no		nein / no
ExcercisePoint	optional		optional		nein / no		nein / no
WorkoutPoint	ja / yes		nein / no		nein / no		nein / no
MobilePoint	optional		optional		nein / no		nein / no
GroupPoint*	optional		optional		nein / no		nein / no
CirclePoint**	optional		nein / no		nein / no		nein / no
OutdoorPoint*	optional	möglich/ possible	optional	möglich/ possible	nein / no	möglich/ possible	nein / no
WebPoint	optional		optional		nein / no		nein / no
InfoPoint*	optional		optional		nein / no		nein / no
ForcePoint***	optional		nein / no		nein / no		nein / no
BrainPoint***	optional		nein / no		nein / no		nein / no
ManagerPoint	optional		optional		nein / no		nein / no
Service, Support etc.	ja / yes		ja / yes		ja / yes		nein / no
gym80-UPDATE	ja / yes		ja / yes		ja / yes		nein / no
gym80-Software BACKUP	optional		optional		optional		nein / no

\* gemeinsam auf einem Rechner instalierbar / installable together with one computer  
 \*\* als Zusatzfunktionalität von GroupPoint / as additional functionality of the GroupPoint  
 \*\*\* als Zusatzfunktionalität von WorkoutPoint / as additional functionality of the WorkoutPoint

NOTIZEN / NOTES

//





Konzepte  
Concepts



## Der medizinisch fundierte Zirkel für Kraft, Kardio und Koordination. The medically-based circle for strength, cardio and coordination.

// Unser Zirkelkonzept K<sup>3</sup> ist ganz daraufhin entwickelt worden, dass alle wichtigen Elemente aus den Bereichen Kraft-, Kardio- und Koordinationstraining abgedeckt werden. Und das bei nur 60 m<sup>2</sup> Platzbedarf. K<sup>3</sup> garantiert bis zu zwölf Personen gleichzeitig ein ausgewogenes Ganzkörpertraining auf medizinischer Grundlage. Zu unserem Konzept gehört natürlich auch, dass alle Kraftgeräte nach MPG-Richtlinien hergestellt werden – speziell für den Reha-Bereich. Dank der im Konzept enthaltenen gym80-Software können Sie den Trainingsbetrieb außerdem exakt steuern, erfolgreicher gestalten und dokumentieren.

// Our K<sup>3</sup> circle concept has been especially designed to cover all the main aspects of strength, cardio and coordination training. And it takes up just 60 m<sup>2</sup> of floor space. K<sup>3</sup> guarantees balanced whole-body training based on medical principles for up to twelve people at the same time. All strength equipment included in our concept has of course been produced in accordance with the guidelines of the German Medical Devices Act (MPG) – especially for the rehabilitation area. With the gym80 software you can control the training and usage frequency more precisely.

### // Komponenten / Components

Sieben Kraftstationen der Serie gym80 SYGNUM Medical (nach MPG-Richtlinien hergestellt) / Vier Kardiostationen SCIFIT Ausdauertraining / Eine Koordinationsstation Haider Posturomed / gym80-Software mit lückenloser Trainingsdokumentation und voller Kontrolle der Bewegungsausführung / Seven strength stations from the gym80 SYGNUM Medical series (produced according to MPG guidelines) / Four SCIFIT endurance training cardio stations / One Haider Posturomed coordination station / gym80 software with complete training documentation and full control of the motion sequence





# High Performance Fussballkonzept

## High Performance - Soccer Concept

// Das SYGNUM High Performance Fußballkonzept bietet Fußballvereinen eine perfekte Produktzusammenstellung und damit die beste Voraussetzung für ein effektives und physiologisches sportartspezifisches (Kraft)-Training. Für alle leistungsrelevanten Anforderungen bietet das Fußballkonzept ein spezielles Gerät. Von der Schusskraft über die Sprungkraft bis hin zu Ausgleichsübungen bei muskulären Dysbalancen – mit dem SYGNUM High Performance Fußballkonzept können Sie sicher sein, das bestmögliche Gesamtpaket für eine stetige Verbesserung in allen Leistungsbereichen zu bekommen.

Mit dem FC Schalke 04, Bayer Leverkusen und dem 1. FC Köln haben bereits drei Bundesligisten dieses Konzept in Anspruch genommen. Im Gelsenkirchener Reha- und Trainingszentrum „medi-cos.AufSchalke“ kommt sogar eine weltweit einzigartige Weiterentwicklung zum Einsatz, die in enger Kooperation mit der medizinischen Sportabteilung des Bundesligisten konzipiert wurde. In diesem Konzept ist der Sprinttrainer von gym80 International integriert, eine spezielle Trainingsmaschine, die zur Verbesserung der Sprintfähigkeit und Antrittsschnelligkeit entwickelt wurde. Beim Training mit dem Sprinttrainer läuft der komplette Bewegungsablauf schwebend ab. Darüber hinaus wurden für „medi-cos.AufSchalke“ mehr als die Hälfte der Trainingsgeräte speziell auf die Bedürfnisse der Profi-Fußballer und der medizinischen Abteilung abgestimmt. Dazu zählt unter anderem eine stehende Bein Streck-Maschine, die die Schusskraft der Fußballer verbessert und eine verlängerte Beinpresse speziell für explosive Sprungkraftübungen.

Optional hilft die gym80-Software bei Trainingsplänen, Gesundheits- und Leistungschecks und bietet so eine optimale Leistungskontrolle aller Spieler.

### // Komponenten / Components

Fußball-Kickmaschine / Sprinter-Maschine / Max Rack für Krafttraining / Liegende Beinpresse Spezial / Duale Beinpresse Spezial / Sprungturm mit Kraftmessplatte / gym80-Software / Posturomed Therapiegerät / Football kicking machine / Sprinter machine / Max Rack for strength training / Horizontal leg press special / Dual leg press special / Jumping tower with strength measurement plate / gym80 software / Posturomed therapeutic device

// The SYGNUM High Performance soccer concept is designed to offer soccer clubs the perfect collection of machines to ensure effective and physiological sport-specific (strength) training. The soccer concept offers a special machine to address each requirement. From kicking power to jumping ability, as well as a range of exercises to alleviate muscular imbalances - the SYGNUM High Performance Soccer concept provides you with the best all-round package to ensure continuous improvement of all aspects of performance.

The German premier league clubs Schalke 04, Bayer Leverkusen and Cologne are already using this concept. The “medicos.AufSchalke” rehabilitation and training center in the German town of Gelsenkirchen is using a unique new development, designed in close cooperation with the soccer club’s medical sports department. The concept involves the gym80 International Sprint Trainer, a special machine designed to improve sprinting power and acceleration speed. The Sprint Trainer covers the entire motion sequence. On behalf of “medicos.AufSchalke”, we have also tailored more than half of the training equipment to the specific needs of professional soccer players and the medical department. Including a standing leg extension machine to boost players’ kicking strength, and an extended leg press specially designed for explosive jumping power exercises.

As an option, the gym80 software can support training plans, health and performance checks, to monitor all aspects of players’ performance.





## Cable Art Trainingskonzept

### Cable Art Training Concept

// Das Cable Art Trainingskonzept bietet deutlich mehr Variationsmöglichkeiten als das Training mit bekannten Kraft- und Kabelzugmaschinen und ist dadurch die Alternative für abwechslungsreicheres und anspruchsvolleres Training. Alle sechs Geräte der Cable Art Serie ermöglichen eine natürliche Bewegungsausführung und trainieren sämtliche Muskelgruppen in einem funktionellen Trainingsablauf. Die Koordinationsfähigkeit, die Balance und die Körperstärke werden dadurch gezielt trainiert. Mit dem Cable Art Trainingskonzept kann das Studio individuell auf die Zielgruppe zugeschnittene Gruppentrainingsprogramme und -konzepte anbieten, wie z. B.: Allgemeine Fitness, Gewichtsreduktion, Box-Zirkel und Fußball-Zirkel.

// Training with Cable Art offers multiple exercise variations in addition to regular strength and cable machines. Cable Art creates varied and progressive training options; the movement pattern is not isolated as conventional strength machines but in a natural curve. With six Cable Art machines all muscle groups can be trained in a functional training sequence. The workout improves and strengthens coordination skills, increases physical activity and energy expenditure. Coordination, balance and body strength are trained as one. With Cable Art gyms can offer group training programs and concepts, individually tailored to the target group, e.g. general fitness, weight reduction, boxing circle and soccer circle.

#### // Komponenten / Components

Personal-Trainer-Coaching 1:1 / Individual-Training und (Klein-)Gruppentraining realisierbar / Geeignet sowohl für junge, als auch für ältere Nutzer / Zielgruppenspezifische Programme für Kraft-, Bewegungs- und Koordinationsverbesserung / Zusätzliches Return-on-Investment Tool durch Angebote für externe Interessenten / Personal-Trainer-Coaching 1:1 / Individual-Training and (small) group training are possible / Suitable for young as well as for older people / Target group oriented programs for enhancement of strength, motion and coordination strength / Additional Return-on-Investment Tool by offers for external interested parties





## // Impressum

### **gym80 International GmbH**

Wiesmannstraße 46  
45881 Gelsenkirchen  
Fon +49-209-9 70 64 0  
Fax +49-209-9 70 64 41  
[www.gym80.de](http://www.gym80.de)

### **Konzeption**

gym80 International GmbH

### **Texte**

gym80 International GmbH  
Vogelsang Konzeptagentur

### **Gestaltung**

Simone Steffens / [www.g-works.de](http://www.g-works.de)

### **Fotos**

C. Fein / D. Hoffmann / H. J. Meier

### **Druck**

Druckhaus Duisburg OMD GmbH

### **Stand**

Juli 2010

Irrtümer und technische Änderungen  
vorbehalten.  
Errors and technical changes excepted.





